

City of Stratford Newsletter

Summer 2023



TIDBITS OF INFORMATION

Electrical Outage Procedures If experiencing an electrical power outage during City Hall's business hours of 8:00 – 4:30 p.m., call 515-838-2311. When experiencing an electrical power outage after hours at your place of residence, call Maintenance Supervisor, Brad Larson, 641-373-7676. If the whole town is experiencing an electrical power outage and Maintenance doesn't answer, call Hamilton County Dispatch at 515-832-9500; or Midland Power Cooperative's emergency number, 1-800-286-2268. If all else fails, call 911.

City Council Members are Carol Bergman, Catherine Bergman, Terry Bryan, HT Buie, Brian Ouverson, and a mayor vacancy. Council meetings are held the second Monday of every month at City Hall at 7:00 p.m.

City Website Check out the City of Stratford's website where you can subscribe to alerts and public notices!

City Hall will be closed on Monday, September 4th, 2023, in observation of Labor Day.

Call 811 A few days prior to digging call 800-292-8989 or 811: Iowa One Call. There is no charge to call for locating services.

Stratford Public Library's Fall 2023 Classes

Thurs, Aug 31: 1 pm – Iris Paper Folding

Thurs, Sep 21: 1 pm – Wool Felted Bowls –
taught by Becky Blair

Thurs, Oct 26: 9 am-4 pm – Table
Runner

Thurs, Nov 30: 1 pm – Tin Punch
Ornament

-Classes are \$5 each, due at time of registration. Class sizes limited to the first 10 people registered. Class fees are non-refundable.

ART
is for everyone



Contact

Stratford City Hall

805 Shakespeare Ave, PO Box 218

Stratford, IA 50249

Phone: 515-838-2311 Fax: 515-838-2315

Email: cityofstratford@globalccs.net

Website: stratfordiowa.com



NOTICE TO ELECTRIC UTILITY CUSTOMER

The Iowa Utilities Board (IUB) is a utility regulatory agency. If you have questions or complaints regarding your utility service, you may contact a utility representative at City of Stratford, 805 Shakespeare Ave., Stratford, IA 50249, 515-838-2311, or email cityofstratford@globalccs.net. If your complaint is related to service disconnection, safety, or renewable energy, and we do not resolve it, you may request assistance from the Iowa Utilities Board: call 877-565-4450 (toll free); or write to 1375 East Court Avenue, Room 69, Des Moines, IA 50319-0069; or email customer@iub.iowa.gov. Low-income customers may also be eligible for free legal assistance from Iowa Legal Aid and may contact Legal Aid at 1-800-532-1275.

FAQ's on Fluoride in the Stratford Municipal Water Supply

Is Stratford's Water Safe to Drink? Yes! The notices sent quarterly with the newsletters (and shown below) contain the required wording written by the Iowa Department of Public Health. Community water systems that exceed the fluoride level of 2.0 mg/L (the EPA minimum level) must provide special fluoride public notice to persons served. A recent sample taken from Stratford's water supply contained a fluoride level of 2.47 mg/L.

Does Stratford Add Fluoride to the Drinking Water? No. The fluoride in Stratford's water is naturally occurring. This water supply obtains its water from the limestone and dolomite of the Mississippian Aquifer. The aquifer was determined to have low susceptibility to contamination because the characteristics of the aquifer and overlying materials provide natural protection from contaminants at the land surface.

What is an Unsafe Fluoride Level? The maximum level set by the Environmental Protection Agency (EPA) is 4.0 mg/L. Drinking water containing more than 4.0 mg/L can increase the risk of certain health issues. Stratford's drinking water does not contain unsafe fluoride levels, but Stratford is required to notify persons served when a sample exceeds the 2.0 mg/L minimum.

~~~~~ IMPORTANT INFORMATION ABOUT YOUR DRINKING WATER ~~~~~

This notice being sent by the Stratford Muni Water Dept. PWSID# 4051002. Elevated Fluoride Levels Detected. Fluoride in children's drinking water at levels of approximately 1 mg/L reduces the number of dental cavities. However, some children exposed to levels of fluoride greater than about 2.0 mg/L may develop dental fluorosis. Dental fluorosis, in its moderate and severe forms, is a brown staining or pitting of the permanent teeth, or both.

Because dental fluorosis occurs only when developing teeth (before they erupt from the gums) are exposed to elevated fluoride levels, households without children are not expected to be affected by this level of fluoride.

Families with children under the age of nine are encouraged to seek other sources of drinking water for their children to avoid the possibility of staining and pitting.

Your water supplier can lower the concentration of fluoride in your water so you will still receive the benefits of cavity prevention while the possibility of stained and pitted teeth is minimized. Removal of fluoride may increase your water costs. Treatment systems are also commercially available for home use. Information on such systems is available at the address given by your public water supplier. Low fluoride bottled drinking water that would meet all standards is also commercially available.

For more information, please contact Stratford City Hall Water Department at 515-838-2311. Some home water treatment units are also available to remove fluoride from drinking water. In Iowa, home water treatment units are regulated under 641—Chapter 14, with the water treatment unit registration program administered by the Iowa Department of Public Health's environmental health division. In addition, you may call the National Sanitation Foundation (NSF) International, at 1-877-867-3435. *Please share this information with all the other people who drink this water, especially those who may not have received this notice directly (for example, people in apartments, nursing homes, schools, and businesses).*

SEASONAL REMINDERS

The Stratford would like to remind residents **not to blow grass, leaves,** or other debris into the street. These can potentially cause clogging of the storm sewers which may result in flooding and can result in costly repairs which are ultimately paid for by the taxpayers. Rain waters push grass, leaves and other debris that have blown into the street, down the curb line and into the storm drains. Stratford's Code of ordinance is as follows:

135.03 PLACING DEBRIS ON. It is *unlawful* for any person to throw or deposit on any street or alley any glass, glass bottle, nails, tacks, wire, cans, trash, garbage, rubbish, litter, offal, **leaves, grass,** or any other debris likely to be washed into the storm sewer and clog the storm sewer, or any substance likely to injure any person, animal, or vehicle.
(Code of Iowa, Sec. 321.369)

Storm drains and storm sewers need to remain clear of grass, leaves, and other debris to allow storm waters to leave your area and drain out through the storm sewer system rather than backing up and causing flooding in your area.

If you have grass clippings and yard debris the city has a **yard waste only** site for the citizens of Stratford. Come up to City Hall and ask for a key to access the city owned debris site. Anyone living within Stratford's city limits may take **yard debris, grass clippings, leaves, and small branches no larger than 4 inches in diameter,** to the site.

Grain Bin Clearance Guidelines

Thinking about building a grain bin?

Source: The 2017 Edition National Electrical Safety Code (NESC), the 2012 NESC, and the American National Standards Institute (ANSI C2-2012).

If you're planning to build or move a grain bin, either on your property or for someone else, you need to be familiar with Iowa's law on required distances from overhead electric lines. This law was put in place to provide protection from the hazard of contacting overhead electric lines to anyone working around grain bins with augers, elevators, or other equipment.

The drawings inside this brochure show the specific clearance requirements related to permanently installed augers and portable augers. There must be at least 18 feet between the top of any grain bin and any overhead electric lines. These distances were developed by the American National Standards Institute. Figure 232.4(b) can be found in the 2017 Edition National Electrical Safety Code (NESC) and the 2012 NESC. As your electric service provider, we're responsible for ensuring that these specifications are met. In fact, in any situation where minimum clearance requirements are not observed, the utility may refuse electric service.

So if a new grain bin is on your list of projects, please give us a call. We will work with you in developing a site plan for your project.

Fig. 234-4(a) -- Clearance Envelope for Grain Bins

Filled by Permanently Installed Augers, Conveyors, or Elevators

- P = probe clearance 5.5m (18 ft.)
- H = horizontal clearance 4.6m (15 ft.)
- T = transition clearance
- V₁ = vertical clearance above a building required by Rule 234C (Table 234-1)
- V₂ = vertical clearance above land required by Rule 232B (Table 232-1 or 232-2)

Fig. 234-4(b) Clearance Envelope for Grain Bins Filled by Portable Augers, Conveyors, or Elevators

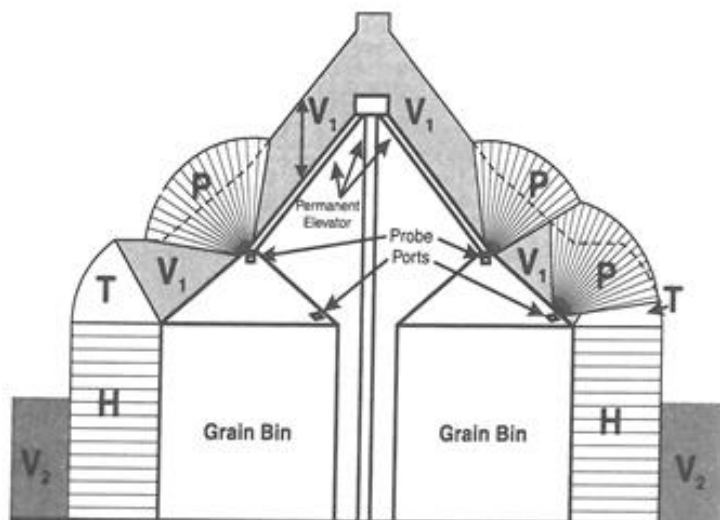
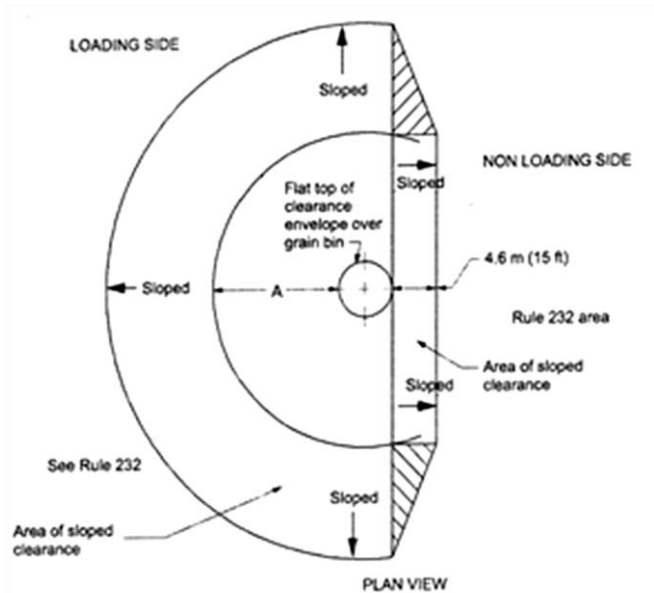
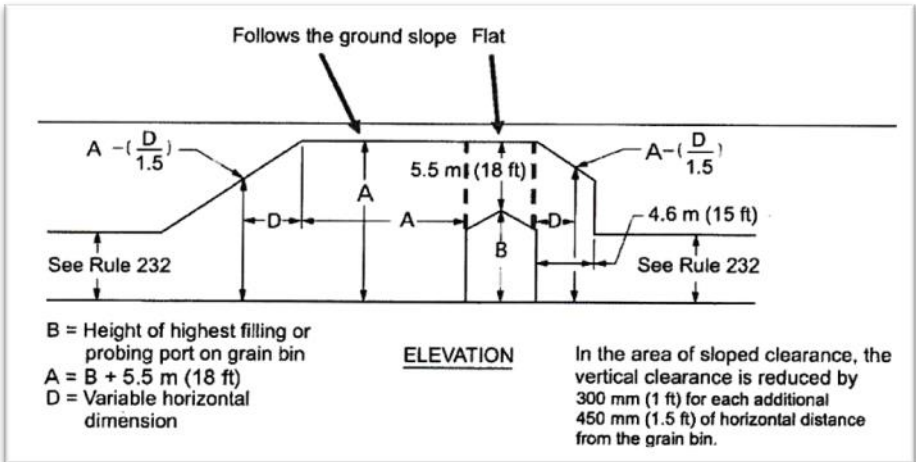

STRATFORD MUNICIPAL SWIMMING POOL

The 2023 pool season will come to an end August 20TH, 2023

The City of Stratford thanks you for your patronage!

Families and folks of all ages from Stratford and surrounding communities have made this pool season an enjoyable one so far. Our swim lesson program was held the dates of June 19th through 23rd. There were 26 children who participated in this program, ranging in all skill levels. Many toddlers have happily splashed in the wading pool this year. Kids have also really enjoyed the concession stand; swimming burns up a lot of energy!

If you are interested or know someone that is interested in being a lifeguard next year, classes are available in Fort Dodge through the Rec Center. Fuller Hall is Webster City usually has classes as well. The lifeguard classes usually start in February and fill up very fast, so plan ahead!

The City of Stratford would like to thank all the patrons that have come out and supported the pool this year. We would also like to give a special thanks to all of the lifeguards who worked hard to keep the pool running this season! If you would like more information about the Stratford Municipal Pool, you can look us up on the City's website at stratfordiowa.com, look us up on Facebook at Stratford Municipal Pool, call City Hall at 515-838-2311 between 8:00 am – 4:30 pm or stop by the pool from 1:00 pm – 8:00 pm during the pool season.



See you at the Stratford Swimming Pool!



Cover Up!

Be mindful of the sun, and always protect your skin by using sunscreen.

Water Safety Tips



Learn CPR

Get Certified in CPR & First Aid



Never Swim Alone

Use the buddy-system, and always tell someone where you're headed.



The Rule of 30!

Wait 30 minutes after eating.



Floaties **Do Not** Replace Life Jackets!

SUMMER SUN AND WATER FUN

MUNICIPAL ELECTION

TUESDAY, NOVEMBER 7th, 2023

The City Council has two positions available on the November 7th ballot.

The City of Stratford will be holding a municipal election this November. Now is the time to start planning for the election. One of the most challenging and exciting responsibilities an individual can assume is to become a mayor or council member. The business of city government and local leadership presents a unique opportunity to resolve issues, accomplish goals, and affect the future of your community.

Mayor and council seats serve a four-year term. The people elected will begin serving as of January 1, 2024. The City of Stratford conducts business on the second Monday of each month. The meetings are held at 7:00 pm, with additional work sessions anticipated during budget season (December - March) and special meetings when necessary. Regular meetings last on average two hours.

Candidates must be eligible electors of the City of Stratford, meeting the same qualifications required to vote and be a resident of the city he or she plans to serve. This means that you must live within the Stratford city limits, be a US citizen, be of legal voting age, and not have been convicted of a felony or other infamous crime for which your rights have not been restored by the governor or by the president of the United States.

Nomination papers may be picked up at either the City Clerk's office or the County Auditor's office or from the Elections Division of the Secretary of State's Office: <http://www.sos.stateia.us/elections/electioninfo/CityElections.html>.

Nominees must obtain ten eligible signatures. Candidate filing for council positions begins on Monday, August 28th and ends with papers due at the City Clerk's office by 5:00 PM on Thursday, September 21st, 2023. Nomination papers are to be turned into the City Clerk's Office.



EXERCISE YOUR RIGHT and VOTE!



ORDINANCE NO. 2023-01. An ordinance amending the Code of Ordinances of the City of Stratford, Iowa, by adding a yield sign on the north east corner and southwest corner of Ross Avenue at the intersection of Ross and Willow, and Stop Sign at the Southwest corner of Commercial Street and Teneyck Avenue.

Section 1. Section Modified. Section 65.02 of the code of Ordinances of the City of Stratford, Iowa, is repealed and the following adopted in lieu thereof:

65.02 STOP REQUIRED. Every driver of a vehicle shall stop in accordance with the following:

- | | |
|------------------------|--|
| 1. Park Street. | Vehicles traveling north on Park Street shall stop at Tennyson Avenue. |
| 2. Byron Street. | Vehicles traveling north on Byron Street shall stop at Tennyson Avenue. |
| 3. Moore Street. | Vehicles traveling on Moore Street shall stop at Milton Street. |
| 4. Tennyson Avenue. | Vehicles traveling west on Tennyson Avenue shall stop at T intersection at west edge of City limits. |
| 5. Tennyson Avenue. | Vehicles traveling west on Tennyson Avenue shall stop at Adams Street. |
| 6. Byron Street. | Vehicles traveling south on Byron Street shall stop at Tennyson Avenue. |
| 7. Goldsmith Street. | Vehicles traveling east on Goldsmith Street shall stop at Teneyck Avenue. |
| 8. Burns Street. | Vehicles traveling north or south on Burns Street stop at Tennyson Avenue. |
| 9. North Street. | Vehicles traveling east on North Street shall stop Shakespeare Avenue. |
| 10. Burns Street. | Vehicles traveling north on Burns Street shall stop at Milton Street. |
| 11. Commercial Street. | Vehicles traveling east on Commercial Street shall stop at Teneyck Avenue. |



Section 2. Section Modified. Section 65.05 of the code of Ordinances of the City of Stratford, Iowa, is repealed and the following adopted in lieu thereof:

65.05 YEILD REQUIRED

- | | |
|--------------------|---|
| 1. Avon Street. | Vehicles traveling north on Avon Street shall yield at Dryden Street. |
| 2. Avon Street. | Vehicles traveling on Avon Street shall yield at Tennyson Avenue. |
| 3. Byron Street. | Vehicles traveling north on Byron Street shall yield at Dryden Street. |
| 4. Pollock Street. | Vehicles traveling west on Pollock Street shall yield at Moore Street. |
| 5. Moore Street. | Vehicles traveling on Moore Street shall yield at Tennyson Avenue. |
| 6. Moore Street. | Vehicles traveling north on Moore Street shall yield at Dryden Street. |
| 7. Moore Street. | Vehicles traveling south on Moore Street shall yield at Goldsmith Street. |
| 8. Burns Street. | Vehicles traveling south on Burns Street shall yield at Goldsmith Street. |
| 9. Ross Avenue. | Vehicles traveling east on Ross Avenue shall yield at Willow Street. |
| 10. Ross Avenue. | Vehicles traveling west on Ross Avenue shall yield at Willow Street. |



Section 3. Severability Clause. If any question, provisions, or part of this ordinance shall be adjudged or unconstitutional, such adjudication shall not affect the validity of the ordinance as a whole or any section, provision or part thereof not jut adjudged invalid or unconstitutional.

Section 4. When Effective. This ordinance shall be in effective after passage, approval and publication as provided by law.

PASSED and approved by the City Council of Stratford, Iowa, this 10th day of July 2023. s/Larry Runyan, Mayor / attest/Kim Leeds, City Manager/Clerk.

Water Conservation Tips

That Keep Things Green



Nighttime Water Schedule

The hot summer days means that water is best used at night.



Laundry Day!

Establish a Laundry Day at home.



Locate Those Leaks

Even a little drip can be costly!



Reduce Shower Time

Less than 10 minutes.



Focus on Faucets

Install aerators for flow restrictions on bathroom and kitchen faucet heads



Water Service Line Inventory – SURVEY FORM

The City of Stratford, along with every municipality, has been tasked with inventorying every service line within the city as a part of an IA DNR/State requirement. We need help from you, residents, and business owners, to identify private service line material. Please fill out this short survey to help us complete our inventory in an efficient manner. If you have any questions, please call City Hall at 515-838-2311.

Contact Information

Name _____

Phone _____

Property Information

Address _____

Year Built Before 1988 After 1988

Homes built after June 1988 are not subject to inspection due to the banned use of lead water lines

Water Line Material Lead Galvanized Copper Plastic

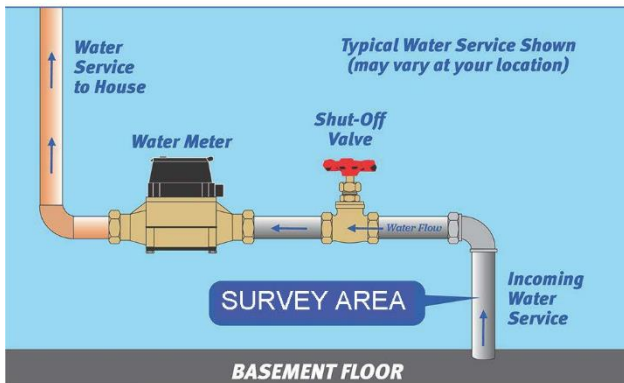

Lead



A dull, silver-gray color that is easily scratched with a coin. Use a magnet - strong magnets will not cling to lead pipes.

Galvanized



A dull, silver-gray color. Use a magnet - strong magnets will typically cling to galvanized pipes.

Copper



The color of a copper penny.

Plastic



White, rigid pipe that is joined to water supply piping with a clamp.

Return this for to City Hall, 805 Shakespeare Avenue, as soon as possible.

THANK YOU for your help by providing your information!

City of Stratford

805 Shakespeare Avenue
Stratford, IA 50249-0218
Phone: 515-38-2311
cityofstratford@globalccs.net
Hours M – F 8:00 am – 4:30 pm

PRSORT STD
U.S. POSTAGE
PAID
STRATFORD, IA
PERMIT #15

Meet our new Maintenance Staff!

Brad Larson is a Stratford native who grew up on a farm just west of town. He is the son of Wayne and Carol Larson. He has one brother Jay, and a daughter that lives in Texas. Brad is coming to the City of Stratford as our new Maintenance Supervisor and is bringing 25 years of maintenance experience with him from the City of Iowa Falls. Brad also is certified in water and wastewater and has his certified pool operator's license to help with our public pool. If you see Brad out and about, please help us in welcoming him back town!

Larry Runyon worked for the City of Stratford as the maintenance supervisor for 25 years before retiring in July of 2013. He took the mayor position in January of 2018 and served as the town's Mayor until July of 2023. Larry resigned as Mayor at a special meeting on July 21st after taking the part-time maintenance position to come back to work for the city. Larry & his wife Kim have been long time residents of Stratford, raising their kids Jeremy and Jason here. Larry brings a ton of knowledge back to the city with him and we are happy to have him back on staff!

Skip the late fees & never miss a payment again! Sign up for automatic withdrawal from your bank account to pay your utility bill by contacting City Hall at 515-838-2311.